

Model D335

Backdraft Damper • 2" Deep • Single Thickness Blades • Extruded Aluminum

STANDARD CONSTRUCTION

- FRAME:** .081" thk. (nominal) extruded aluminum, 6063-T52/T6 alloy, 1¹/₁₆" x 2" x 3¹/₈" flanged frame on all sides.
- BLADES:** Extruded aluminum, 6063-T6/T52 alloy, .081" thk. Designed for strength and low leakage with overlapping edges.
- AXLES:** 1/2" dia. extruded aluminum, pin-lock design.
- SEALS:** Silicone rubber off-set leg at blade edges. None at jambs.
- BEARING:** Celcon bearing material so that there will be no metal to metal friction.
- LINKAGE:** Face mounted in the airstream.
- DAMPER FACE:** Full jamb section with blades, head and sill contained in jambs.
- TEMP. LIMITS:** -40°F to 190°F.
- FINISH:** Factory mill.

OPTIONS

- Blade: 5¹/₁₆" blade on 5¹/₂" centers.
- Screens: Bird or Insect screens available.
- Optional frame types shown below.
- Counterweights: Adjustable for infinite opening pressures. Optional locations available. See Note 3 for details.

NOTES

1. Nominal deductions will be made to the opening size given.
2. When a non-symmetrical frame cross section is specified (i.e. Flanged), specify the flange/airflow orientation.
3. For optional counterweights, specify to assist or resist opening. Also, specify location internally (on blades) or externally (on extended shaft).
4. Approximate shipping weight is 6.5 lbs./sq.ft.

DAMPER SIZES

Min Panel	Max Panel
8"W x 8"H Body Size	60"W x 72"H Body Size

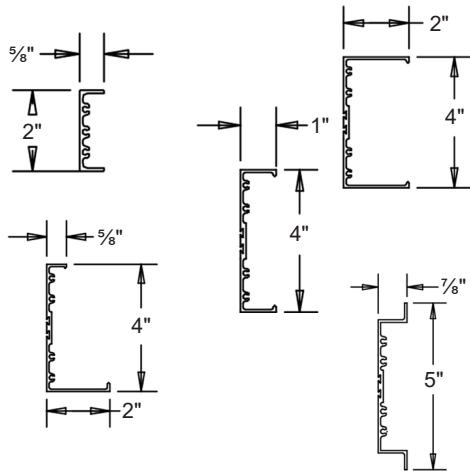

Available Frame Options

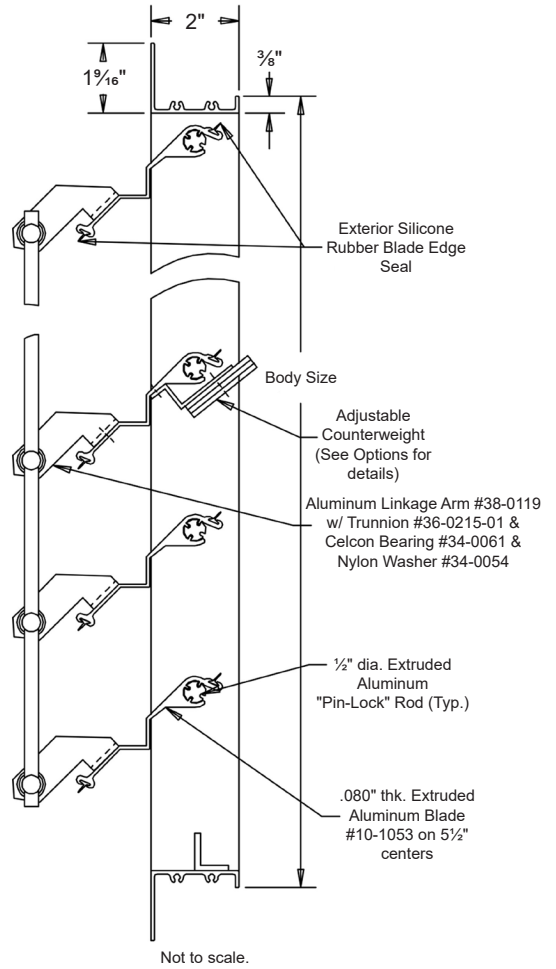

Not to scale.

Item #	Qty	Opening Size		Damper Size		Mullion			
		Width	Height	Width	Height		EDR:	ECN:	Job:
Arch. / Eng.:							EDR:	ECN:	Job:
Contractor:							Date:	DWN:	DWG:
Project:							Date:	DWN:	DWG:



Union Made

In the interest of product development, Louvers & Dampers reserves the right to make changes without notice.

www.louvers-dampers.com

450 Riverside Drive • Wyalusing PA, 18853 • Phone 570-746-1888 • Fax 570-746-9286



PERFORMANCE DATA

Without Ductwork

Damper installed per AMCA 500
Fig. 5.5 (Wall Mounted)

Pressure is corrected to .075 lb./cu.ft.
air density

Operational Pressures

Start to Open - .04 inches w.g.
Fully Open - 1.44 inches w.g.

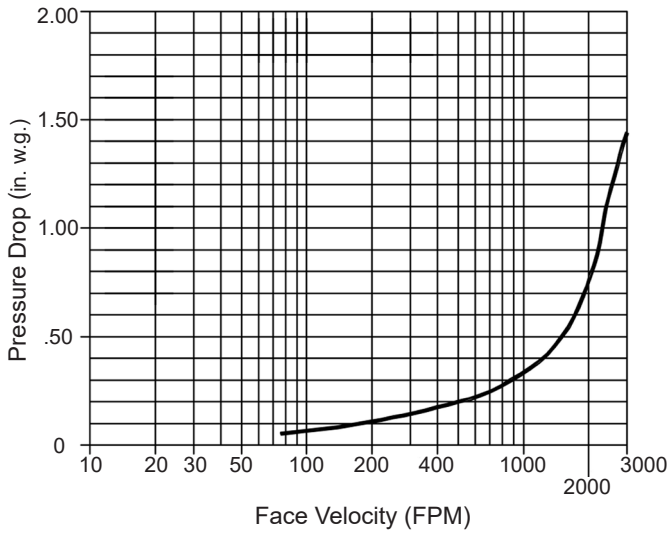

With Ductwork

Damper installed per AMCA 500 Fig.
5.3 (Ductwork installed upstream and
downstream of damper)

Pressure is corrected to .075 lb./cu.ft.
air density

Operational Pressures

Start to Open - .03 inches w.g.
Fully Open - .44 inches w.g.

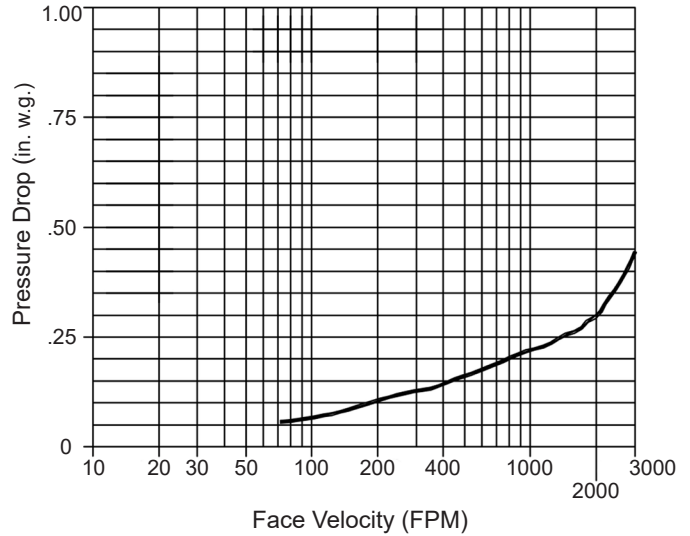

Typical Performance for Model B335 Backdraft Damper
Size tested 36" x 36", furnished with counterweight to assist opening.